

CARTON CLOSING STAPLER

Model: USC1634MA

Model: USC1634M

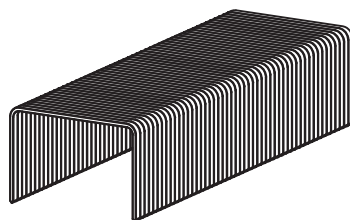

APPLICABLE FASTENER SIZE

Shank Dia.: 16 Ga.

Crown Size: A-Type: 1-3/8"
C-Type: 1-1/4"

Length: 5/8" ~ 3/4"

APPLICATIONS:

Cardboard box packaging.

TOOL SPECIFICATION

Weight:	Dimensions:	Load Capacity:	Operating Pressure:
3.75lbs / 1.7kgs	11.5 x 4.53 x 14.25" 293 x 115 x 363mm	100 staples	By hand

Model: USC1634CA

Model: USC1634C

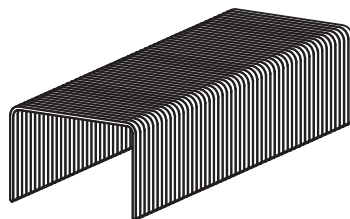
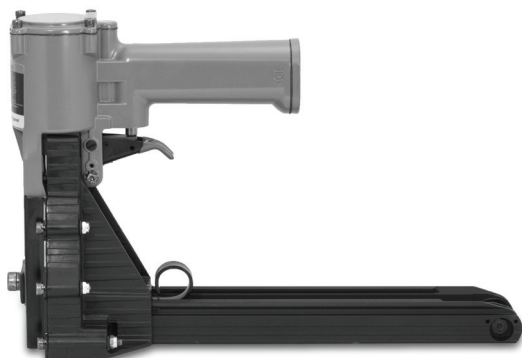

APPLICABLE FASTENER SIZE

Shank Dia.: 16 Ga.

Crown Size: A-Type: 1-3/8"
C-Type: 1-1/4"

Length: 5/8" ~ 3/4"

APPLICATIONS:

Cardboard box packaging.

TOOL SPECIFICATION

Weight:	Dimensions:	Load Capacity:	Operating Pressure:
4.74lbs / 2.15kgs	8.66 x 4.53 x 13.25" 220 x 115 x 336mm	100 staples	70~100 psi (5~7 bar)